



DB201 thru DB207

2.0 A Single-Phase Glass Passivated Bridge Rectifiers

Rectifier Reverse Voltage 50 to 1000V

Features

- The plastic material used carries Underwriters Laboratory flammability recognition 94V-0
- Surge overload ratings to 50 amperes
- Ideal for printed circuit board application
- High temperature soldering guaranteed 260 °C /5 seconds at 5 lbs (2.3kg) tension

Mechanical Data

Case: Molded plastic
 Terminals: Plated leads solderable per MIL-STD-202, Method 208
 Polarity: Marked on body
 Mounting Position: Any
 Weight: 0.34 grams (approx)

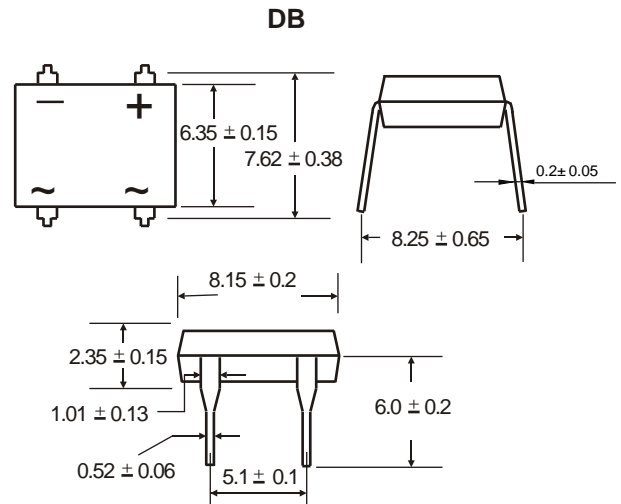

Dimensions in millimeters (1mm =0.0394")

Maximum Ratings & Thermal Characteristics

Rating at 25°C ambient temperature unless otherwise specified, Resistive or Inductive load, 60 Hz.
 For Capacitive load derate current by 20%.

Parameter	Symbol	DB201	DB202	DB203	DB204	DB205	DB206	DB207	Unit
Maximum repetitive peak reverse voltage	V_{RRM}	50	100	200	400	600	800	1000	V
Maximum RMS bridge input voltage	V_{RMS}	35	70	140	280	420	560	700	V
Maximum DC blocking voltage	V_{DC}	50	100	200	400	600	800	1000	V
Maximum average forward rectified output current at $T_A=40^\circ\text{C}$	$I_{F(AV)}$	2.0							A
Peak forward surge current single sine-wave superimposed on rated load (JEDEC Method)	I_{FSM}	50							A
Rating for fusing ($t < 8.3\text{ms}$)	$I^2 t$	6.35							$\text{A}^2 \text{sec}$
Typical thermal resistance per element (1)	$R_{\theta JA}$	58							$^\circ\text{C} / \text{W}$
Typical junction capacitance per element (2)	C_J	25.0							pF
Operating junction and storage temperature range	T_J, T_{STG}	-55 to + 150							$^\circ\text{C}$

Electrical Characteristics

Rating at 25°C ambient temperature unless otherwise specified. Resistive or Inductive load, 60Hz.
 For Capacitive load derate by 20 %.

Parameter	Symbol	DB201	DB202	DB203	DB204	DB205	DB206	DB207	Unit
Maximum instantaneous forward voltage drop per leg at 2.0A	V_F	1.1							V
Maximum DC reverse current at rated DC blocking voltage per element	I_R	10 500							μA

Notes: (1) Thermal resistance from Junction to Ambient on P.C. board mounting.
 (2) Measured at 2.0MHz and applied reverse voltage of 4.0 volts.

Rating and Characteristic Curves ($T_A=25^\circ\text{C}$ Unless otherwise noted)

DB201 thru DB207

Fig. 1 Derating Curve for Output Rectified Current

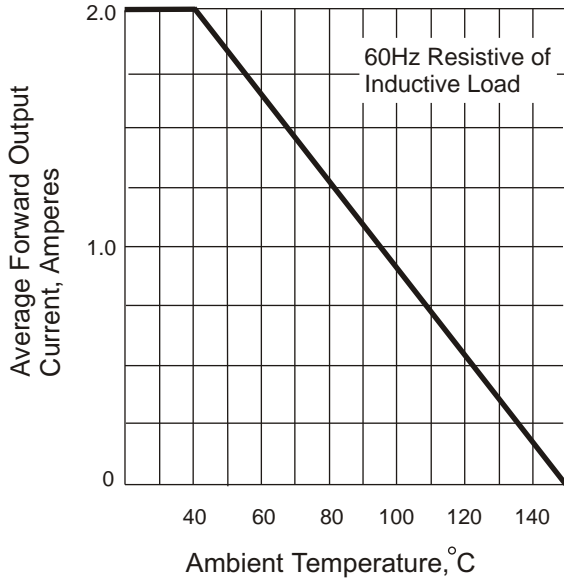

Fig. 2 Maximum Non-repetitive Peak Forward Surge Current

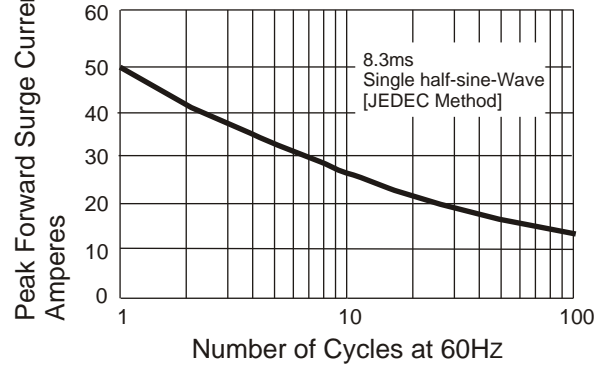

Fig. 3 Typical Instantaneous Forward Characteristics

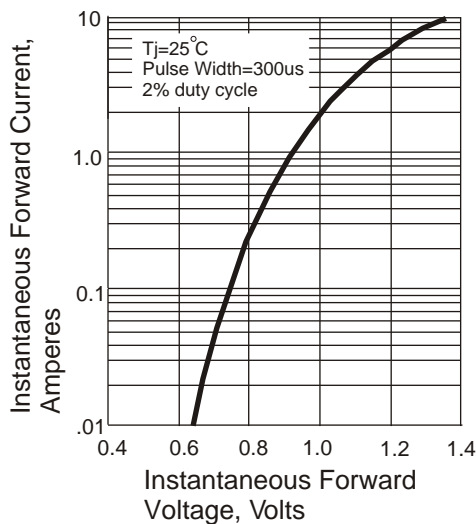

Fig. 4 Typical Revers Characteristics

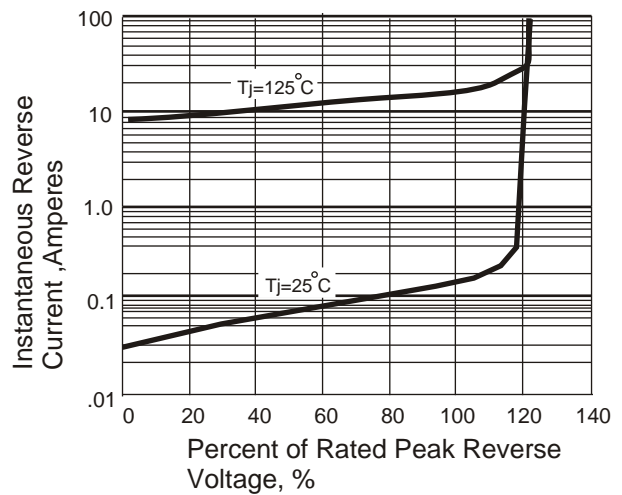

Fig. 5 Typical Junction Capacitance

