



MBRB30100CT thru MBRB30200CT

30.0A Schottky Barrier Rectifiers

Rectifier Reverse Voltage 100 to 200V

TO-263AB

Features

- High frequency operation
- High purity, high temperature epoxy encapsulation for enhanced mechanical strength and moisture resistance
- Guard ring for enhanced ruggedness and long term reliability
- Solder dip 260 °C max. 8 s, per JESD 22-B106

Mechanical Data

- **Package:** TO-263AB
Molding compound meets UL 94 V-0 flammability rating, RoHS-compliant
- **Terminals:** Tin plated leads, solderable per J-STD-002 and JESD22-B102
- **Polarity:** As marked

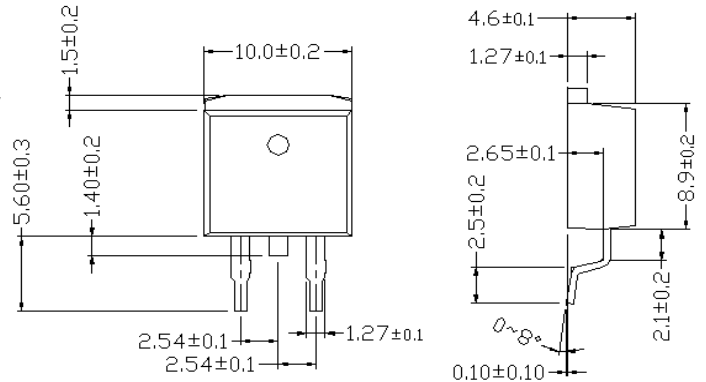

Dimensions in millimeters (1mm =0.0394")

■Maximum Ratings (Ta=25°C Unless otherwise specified)

PARAMETER	SYMBOL	UNIT	MBRB30100CT	MBRB30150CT	MBRB30200CT
Device marking code			MBRB30100CT	MBRB30150CT	MBRB30200CT
Repetitive Peak Reverse Voltage	V _{RRM}	V	100	150	200
Average Rectified Output Current @60Hz sine wave, R-load, Ta=25°C	I _O	A	30		
Surge(Non-repetitive)Forward Current @60Hz half sine-wave, 1 cycle, Ta=25°C	I _{FSM}	A	180		
Current Squared Time @1ms≤t<8.3ms Tj=25°C,	I ² t	A ² s	134		
Storage Temperature	T _{stg}	°C	-55 ~ +175		
Junction Temperature	T _j	°C	-55 ~ +150		

■Electrical Characteristics (Ta=25°C Unless otherwise specified)

PARAMETER	SYMBOL	UNIT	TEST CONDITIONS	MBRB30100CT	MBRB30150CT	MBRB30200CT
Maximum instantaneous forward voltage drop per diode	V _{FM}	V	I _{FM} =15.0A	0.87	0.93	0.95
Maximum DC reverse current at rated DC blocking voltage per diode	I _{RRM1}	mA	V _{RM} =V _{RRM} Ta=25°C	0.15	0.1	
	I _{RRM2}		V _{RM} =V _{RRM} Ta=125°C	20		
Thermal Resistance	R _{θJ-C}	°C/W	Between junction and case	2.0		

Rating and Characteristic Curves ($T_A=25^{\circ}\text{C}$ Unless otherwise noted)

MBRB30100CT thru MBRB30200CT

FIG1: I_o - T_c Curve

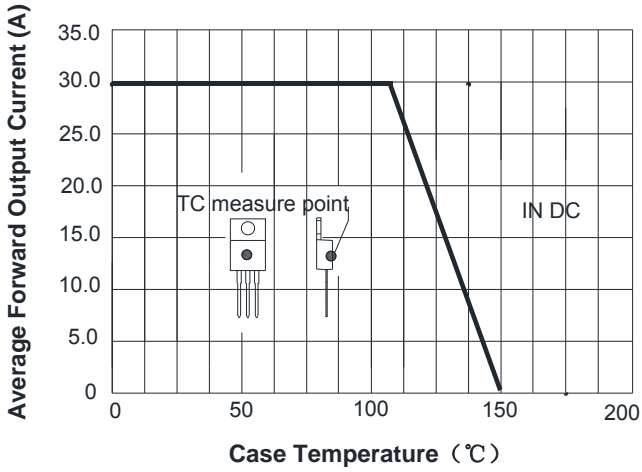

FIG2: Surge Forward Current Capability

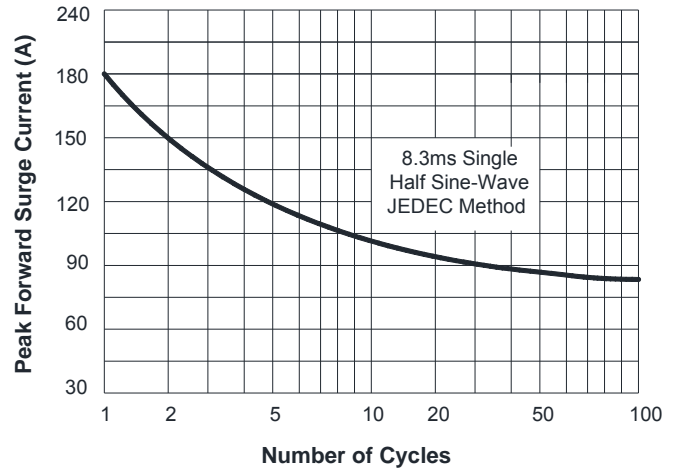

FIG3: Forward Voltage

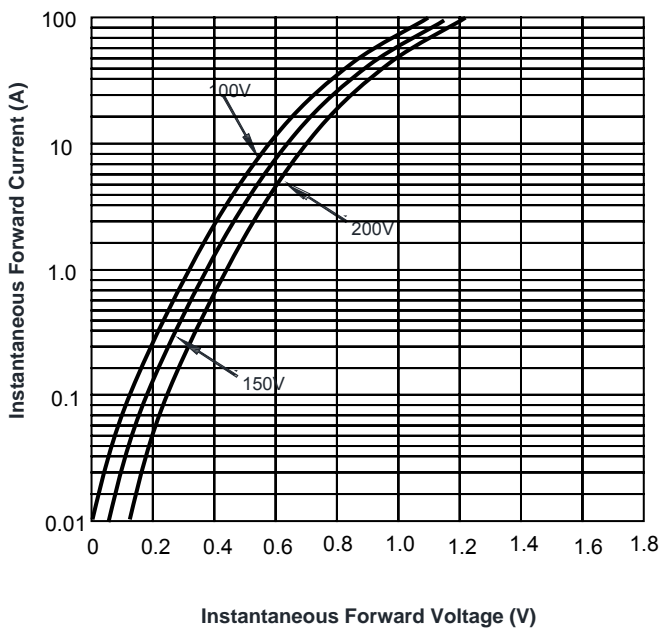

FIG4: Instantaneous Reverse Characteristics

